

NOTE: MINIMUM 20 GPM @ 30 PSI WATER SUPPLY REQUIRED
TOTAL WEIGHT MINUS DRUM - 382lbs

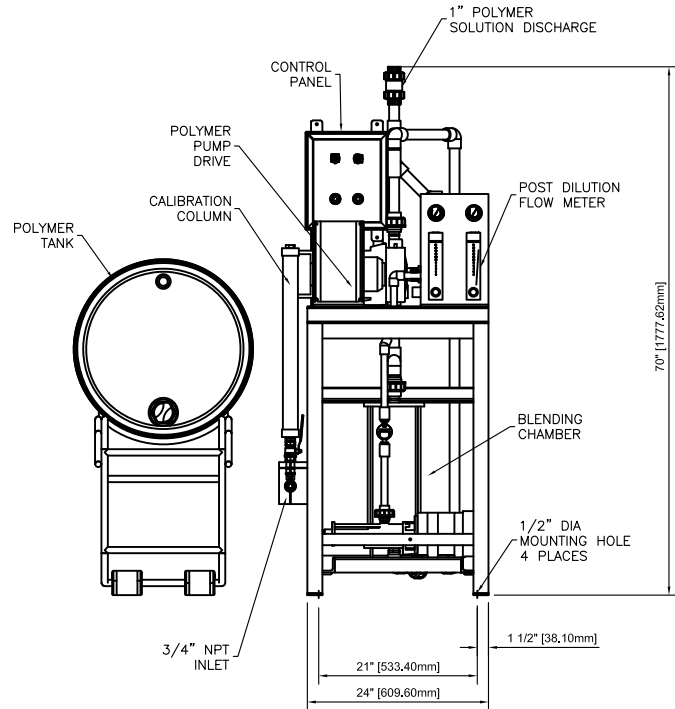

FRONT

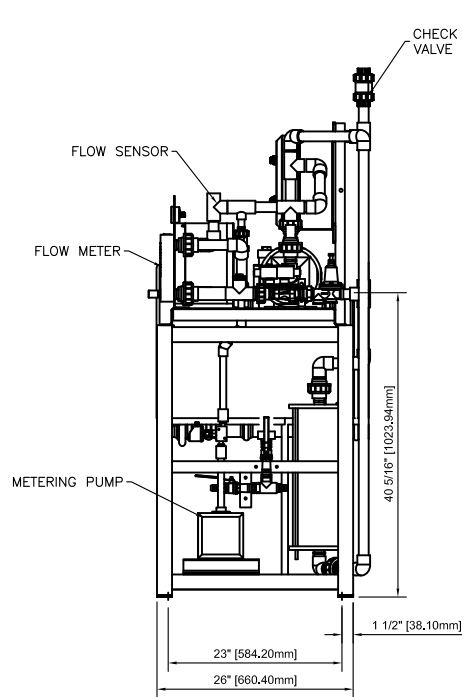

SIDE

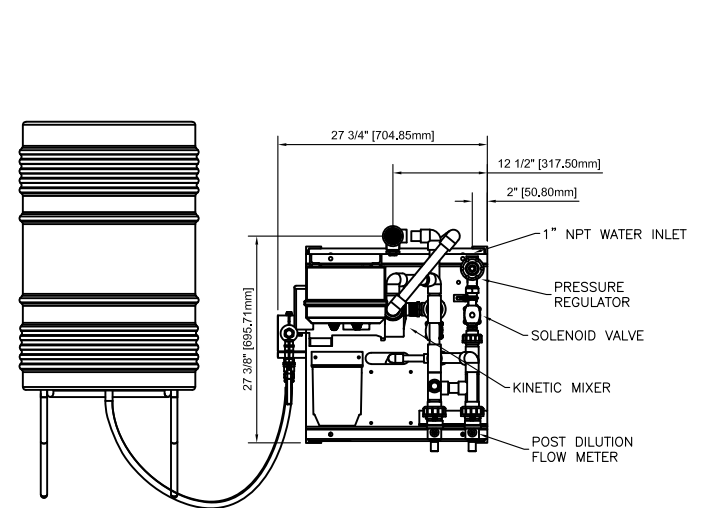

PLAN VIEW

WEBSITE DOWNLOADS ARE FOR REFERENCE ONLY. CONTACT SALES FOR FURTHER INFO.



DRAWN
TMP
APPROVED

G.E.C. TOLERANCES UNLESS
OTHERWISE SPECIFIED

FRACTIONAL DIM $\pm 1/64$
DECIMAL DIM $\pm .005$
ANGLE $\pm 1/2$
SURFACE FINISH 125

CHARTER MACHINE COMPANY 55 WESTER AVE METUCHEN N.J. 08840		
TITLE ROEDOS L-2.20 POLYMER SYSTEM W/ DRUM DOLLY MACHINE VIEWS		
SIZE A	DWG NO. L2,20-02	REV 0
SCALE NONE	SHEET 1 OF 1	

PROPRIETARY: EXCEPT AS OTHERWISE AGREED IN WRITING, THE INFORMATION AND DESIGN DISCLOSED HEREIN ARE THE PROPERTY OF THE CHARTER MACHINE COMPANY AND MUST NOT BE COPIED OR DISTRIBUTED OUTSIDE THE CHARTER MACHINE COMPANY EXCEPT TO AUTHORIZED PERSONS WITH A GENUINE NEED TO KNOW WHO BY THE USE HEREOF ACKNOWLEDGE CHARTER MACHINE COMPANY OWNERSHIP AND AGREE TO MAINTAIN THIS INFORMATION AND DESIGN IN STRICT CONFIDENCE.